

Enhancing Private University Lecturers' Quality Through Tacit Knowledge Sharing: A Case Study in Yogyakarta

Rina Maharani¹
Universitas Mercu Buana Yogyakarta

Dwi Prasetya Nugroho²
Universitas Mercu Buana Yogyakarta

Submitted :20-01-2024, Accepted : 21-02-2025, Published : 19-03-2025

Abstract

Objective research This test will include knowledge, relationships with values, and altruistic conduct. Study This was completed in a private college in Yogyakarta using a quantitative and qualitative approach. Quantitative approach sample lecturer up to 294 persons. Approach qualitative by using three sources to find person leaders in higher education. According to research findings, conduct altruism is the best predictor of desire. Perceived value support is a crucial component of information sharing between lecturers on both an internal and external level. conclusions from the data This calls for the routine discussion of study programs at the lowest structural level, as well as discussions at the faculty and university levels, as well as discussions with party external Good fellow academics or with non-academicians, before activity. Regulations that guarantee quality as a tool for control must be applied to this. All of these ideas are capable of improving lecturer caliber and bringing about the Tri Dharma of Higher Education.

Keywords: Perceived Value, Altruism Behavior , Willingness to Share , Trust, Tacit Knowledge Sharing

Introduction

Lecturer asked that internal professionals perform his duties in accordance with the publication rule from Kemendikbudristek stated in Permenristekdikti Number 51 of 2017 regarding Certification Educator For Lecturer. In addition to being educators, professionals, and scientists, their principal tasks involve transforming, developing, and disseminating information about science, technology, and art through community service, research, and education. Connected with Because knowledge has become the most precious asset, management of knowledge in the educational field is crucial. Expertise is a valuable intellectual asset that is both original and distinctive, and for this reason academic circles have turned to research and practices to spread management expertise. (Gamble, 2020) claim that intellectual property There are two types of knowledge: explicit and tacit. Explicit knowledge is the knowledge that has been gathered and translated into something that can be more easily

understood by others. Tacit knowledge is the knowledge that has been contained within someone's mind in accordance with that person's understanding and experience. This is distinct and special. The most crucial and valuable knowledge is tacit knowledge, which is also challenging to describe. From type knowledge, a company can see more value. System management knowledge is what this is.

Share knowledge tacit, commonly referred to as the way individuals exchange and receive knowledge (Business, 2005), is one of the profound basic concepts studied in management knowledge (Sentika & Arissaputra, 2022). When a group of people collaborates to solve problems and come up with fresh ideas, knowledge can be shared (Nham et al., 2020). Employees frequently exchange information, values, experience, knowledge, and skills relating to the work at hand with others in a way that is neither explicit nor tacit (Wang, 2013). There are various ways for individuals to express their expertise, such as writing and discussing notes regarding data analysis. Informal conversations held during meetings and debates also aid in the development of new information (Gamble, 2020). According to Asbari et al. (2019), lecturers' height can influence students' creativity, innovation, knowledge transferability, and even superiority competitiveness.

The company uses a suite of actions to identify, produce, describe, and share management knowledge that is then used, known about, and learned within the business. As stated by Garcia-Perez et al. (2018), this activity is typically associated to objective organization and address For reaching certain results such knowledge collaboration, performance improvement, excellence competitiveness, and innovation. The core knowledge management concept is How to explore, use, and disseminate knowledge. With this in mind, many organizations manage knowledge as a strategy for creating value, increasing effectiveness and productivity, and creating superior competitive organizations.

The process of creating knowledge in organizations must be understood as a process that organizationally strengthens knowledge created by individuals and its formation is a component

of network knowledge organizations, according to the (Philipson & Kjellström, 2020) view that knowledge created by individuals can always emerge and be expanded by the organization through social interaction where tacit knowledge is changed into explicit knowledge. Refer to view of ownership, where the emphasis is on individual achievement and tacit knowledge inside a certain organization. Temporary related ideas hold that knowledge must be divided in order for it to be valuable, and that knowledge that is hoarded will quickly become outdated (Sentika & Arissaputra, 2022). Knowledge is thus at in context interaction individual through perspective such. Study This attempt aims to embrace an epistemologically-owned perspective of knowing.

In Sentika & Arissaputra, 2022, Polanyi (1966). Make a distinction between implicit and explicit information. Implicit knowledge cannot be easily codified, conveyed, communicated, or documented in a systematic manner using language like words and pictures. This typically consists of technical knowledge, instructions, and processes, as opposed to tacit knowledge, which is rooted in action, commitment, involvement, and context-specific knowledge. According to Polanyi (1966), tacit knowledge is known but difficult to disclose because it has been internalized in lower conscious thought. Tacit knowledge demonstrates a level of information that cannot be made explicit since natural consciousness cannot be accessible. Because of this, Polanyi stated simply that "we know more than we can tell".

The question is, "How knowledge that has owned by individuals in matter This is lecturer as consequence from the learning process without stop, can be shared with all lecturer in institution education?" This is because a common problem in management is that many pieces of knowledge are controlled by a small number of people, and when these people leave the organization (exit), a large organization may lose their knowledge. Because deployment knowledge of the parts from very profitable organization is very vital for success institution education (Asbari et al., 2019; Garcia-Perez et al., 2018; Sentika & Arissaputra, 2022).

Many organizations have not yet or do not recognize the potential hidden knowledge that their members may possess. The findings of the Dhelphi Group's research show that deep knowledge organization is stored with structure. 42% are in the employees' or members' minds (brains), 26% are in paper documents, 20% are in electronic papers, and 12% are in knowledge-based electronics. The level of knowledge management implementation is based on the culture of knowledge sharing. (2018) (Zhao et al.) Opinion that the community's desire to share norms and values with each other, if point satisfying ethical-normative standards, is a major determinant of ability association. Individual interests will therefore be subject to those of the community group once this is discovered. Because sharing knowledge has many benefits that have been realized, even though some employees still lack the motivation to do so (Mohajan, 2019). These workers believe that knowledge should be kept private to ensure the security of their positions and titles within an organization and to prevent them from being replaced. As a result, knowledge is kept in a natural trend that is difficult to reverse. Another reason why people are reluctant to share their expertise is because they believe that doing so will take time and effort, and that alternative activities are more likely to result in greater personal gains and advantages (Natek & Lesjak, 2021).

In light of the foregoing rationale, this study's goal is to test and disseminate knowledge at Private Higher Education (PTS) in Central Java. Election institution education tall is organizations functioning in the field service knowledge and information, according to the context study, that caused institution education tall. To be at the forefront and decisive performance professors and performance institution, learning and sharing information is essential. When compared to other organizations in the public sector and other institutions, institution education stands out as an intriguing phenomenon. It also plays a significant part in numerous innovations.

Additionally, rising height standards place more and more pressure on educational institutions to be able to meet their students' needs, and they have turned into the inspiration

and main source of information for college-high development. This has raised institution education standards. For not only to run activity education alone, but also to become demanded organization research that offers a variety of solutions to issues faced by excellent stakeholders in business, government, or other parties in need. Property knowledge (Matic, Cabrilo, Grubi-Nei, 2017), Szilva, Caganova, Bawa, Pechanova, action management and style management (Krylova, KO, Vera, D. And Crossan, 2016), and characteristics individual like trend individual For believe (Matzler et al., 2006) are just a few of the facilitators and other deterrents from behavior share knowledge that have been reported in literature. Because it's a trend, the lecturer's willingness to impart knowledge will be positively impacted. Perceived values also have an impact on behavior, which will have an overall negative impact on performance, innovation, and college height.

Development of Theory, Concept, and Hypotheses Development of Hypotheses Perceived Value and Share-Willingness

Perceived value is one of the theories concerning mark A information that have been discussed. According to research by Gallarza and Saura from 2006, which is based on Zeithaml's research, the most widely accepted definition of perceived value is: evaluation of a product's utility as a whole based on perception of what is given and received.

Table 1. Perceived Value of the State of the Art and Shareability

No	Researcher	Findings
1	(Mahmood et al., 2020b)	Findings study This conclude that the perceived value of knowledge has an effect to intention to share tacit knowledge.
2	Ahmet Demir, et all, 2020	The result disclose that quality service in a manner direct influence perceived value and satisfaction _ but No influential directly on availability For pay

3	C. Schumacher, 2022	Findings empirical show that culture national in a manner direct influencing willingness to share and moderating effect from problem privacy and the perceived benefits of Willingness to Share
4	Medberg , G. C. (2020),	Studies This identify seven dimensions empirical from mark in use and Grönroos, positive and negative : solution , attitude , convenience , expertise , speed service , flexibility , and cost monetary . Interestingly , dimensions mark this is very overlapping overlapping with dimensions quality service

Source: Data Processed (2025)

H 1: Perceived Value influences willingness to contribute in a favorable way

Behavior of Altruism and Trust

Auguste Comte initially proposed the concept of altruism, defining it as the "principle behave devote self For the interests of others" (Khoa et al., 2020). Exchange social theory explains the psychological underpinnings of altruism (Honeycutt, 2014). Altruism is openness thought as a result of support for fulfilling need live alongside others, according to self-space based perspective (Khoa et al., 2020). Altruism and kindness sociologically make people inclined to put others before themselves and develop individuals Altruism, peer support, and leader support all have a substantial impact on employee trusts, according to research by Khoa et al. (2020). Being willing to serve others without expecting anything in return has a significant association with success in business.

Table 2. Modern research on altruistic behavior and trust

No	Researcher	Findings
1	(Slonim & Garbarino, 2008)	Trust and altruism become behavior important influences _ decision success and growth business .

-
- 2 (Brühlhart & Usunier, 2008) Connection reciprocity , interaction and trust , is different and relevant components _ from preference individual and altruism . Formally test _ explain altruism dominant in support trust and giver more Lots to the poor.
 - 3 (Khoa et al., 2020) From the results study is known that altruism behavior , peer support and leader support influence positive and significant towards employee trusts. In matter characteristics demographics employee , look that behavior voice tend varies in a manner significant depending on position and level education .

Source: Data Processed (2025)

H 2: Altruistic behavior has a beneficial impact on trust

Share-Awareness and Tacit Knowledge Sharing

Will highlight group interests, which are crucial (De Vries et al., 2006). Philosophy will take member groups into particular consideration as the most important aspects influencing its formation aim and performance behavior. Willing to share refers to how much a person is prepared to share their organization's intellectual property with other team members and members. According to Susanty et al. (2016), the fundamentals of sharing knowledge are determined by the individual's will to do so. De Vries et al. (2006) confirmed in their study that this will be related to collection knowledge and donations knowledge. Communication style, job satisfaction, and trust in behavior-sharing performance will all be mediated by attitude-sharing knowledge. In addition, pride, empathy, and the intent to take action are intermediate mediators of how emotions affect will (De Vries et al., 2006).

Table 3. Modern technology Share-Awareness and Tacit Knowledge Sharing

No	Researcher	Findings
----	------------	----------

-
- 1 (Manus et al., 2016) Findings This gave the researchers topology whole from factor KS, and equally offer useful insight _ for manager wants _ increase will For share inside knowledge _ company them .
 - 2 (Du et al., 2012) Studies This see influencing factors _ as far as desire For share information from perspective partnership . Share information template - based and proactive show that when partnership become more close , will For share information template- based is increasing and consequently will For share information become proactive .
 - 3 (Gosain et al., 2004) Willingness For share reflect quality information together , incl accuracy time , accuracy , adequacy , completeness , and reliability . Dimensions this , combined with breadth share information and rate knowledge coordinated involved , influencing _ quality decisions made by the company .

Source: Data Processed (2025)

H 3: The willingness to share has a favorable impact on the sharing of tacit knowledge.

Trust and Sharing of Tacit Knowledge

Tactic information sharing is seen as one of the earliest kinds of intellectual capital with the development of trust (Lin, 2007). Trust must be established in order to foster an organizational culture that encourages sharing of tacit information. Because trust is made up of moral behavior, skill, dependability, and integrity, it goes beyond simple emotional display of faith in others. The point is that trust can boost a team's dedication and level of skill. High trust close ties to engaged staff, happy consumers, and successful businesses. Trust is essential for a successful team effort and task resolution. In addition, trust fosters self-assurance and serves as a lure for open feedback that raises the caliber of information. To put it another way, trust is established through work, which enables organizations to share tacit knowledge and improve both

employee skill levels and the quality of their information. With integrated dynamics trust in the organizational culture's essential values, there will be interaction not only between coworkers but also between management and staff (Nesic & Lalic, 2016).

Table 4. State-of-the-Art Trust and Tacit Knowledge Sharing

No	Researcher	Findings
1	(Ogunmokun et al., 2020)	Analysis results empirical disclose that trend trust relate positive with behavior share knowledge , and behavior share knowledge relate positive with structure organization organic and innovative service .
2	(Holste & Fields, 2010)	Trust influence member staff willing share knowledge tasit , and belief based influence own more influence _ big in a manner significant to willingness For share tacit knowledge , whereas trust based cognition play role more big in willingness For use tacit knowledge .
3	(Samadi et al., 2015)	Study results conclude there is connection between trust organization and sharing knowledge between employee with difference generation . Findings This contribute significant to progress literature knowledge management research because give donation thinking for manager For get more insight _ Good about connection between trust built between _ _ employee multigenerational and sharing knowledge .
4	(Ni & Ganesharatnam, 2022)	Research results This show that share knowledge explicit and tacit effect positive and significant to capability teacher innovation , either in a manner direct nor through mediation learning organization , meanwhile

share influential tacit knowledge positive and significant to capability
teacher innovation through mediation each other believe .

Source: Data Processed (2025)

H 4: Sharing of tacit information is influenced favorably by trust.

Value Perception and Tacit Knowledge Exchange

People are typically motivated to share tacit knowledge after having first-hand experience, and doing so won't diminish value; rather, it will increase it for the owner because it can be more advantageous, such as receiving respect from coworkers, and it can cover dimensions like benefits, uniqueness, usability, and resources. Together, these kindly create a perception of value (Mahmood et al., 2020b). Temporary perspective that is broad regarding Mark will counteract perception that is unique, where the value placed on knowledge will be based on the fourth dimension. In his research, Ignacio (Castaeda, 2015) confirms a positive correlation between perceived value and tacit knowledge sharing.

Table. 5 State-of-the-Art Perceived Value and Tacit Knowledge Sharing

No	Researcher	Findings
1	(Mahmood et al., 2020b)	Share Tacit knowledge is A challenge but give enhancement rapid performance and innovation in organization . Study This highlight the OCB factor and its perceived value of knowledge to share tacit knowledge, the findings concluded significant perceived value to share tacit knowledge
2	(Castañeda, 2015)	Find that the perceived value of knowledge is related direct with intention share knowledge when si divider No lose . Perceived value implies high communication and protection low knowledge . Otherwise , if knowledge considered unique or single , then individual Possible feel

that moment share it , knowledge This Possible lost value . In matter this
, someone No will own intention For share it .

Source: Data Processed (2025)

H 2: Perceived Value Influences Tacit Knowledge Sharing in a Positive Manner

Tacit Knowledge Sharing and Altruistic Behavior

Altruism is action intentional for helping or benefiting others without bringing profit for self myself, and even sometimes make individual must pay (Pfattheicher et al., 2022). action altruistic the is action intentional For helping / benefiting others without bring profit for self myself, and even more motivated by desire For give benefit for others (Solorzano et al., 2022).

Table 6. Altruism Behavior and Tacit Knowledge Sharing in the Present

No	Researcher	Findings
1	(Obrenovic et al., 2020)	Willingness For share own impact directly on sharing tacit knowledge with the mediator altruism . Altruism own influence No direct to share tacit knowledge when norm subjective be a mediator. Findings show that social capital , like altruism effect on sharing tacit knowledge compared with characteristic features prominent personality _ component intrinsic .
2	(Mahmood et al., 2020a)	Share Tacit knowledge is A challenge but give enhancement rapid performance and innovation in organization . Study This explore problem share tacit knowledge of perspective behavior and focus on formation intention and attitude to share tacit knowledge . Along with increasing interest For share tacit knowledge , research This do survey literature systematic and recorded factor key level influencing individuals share tacit knowledge such as OCB and

Perceived Value of Knowledge (PVK) and discuss role they in influencing

Intentions to Share Tacit Knowledge.

- 3 (Shaari et al., 2015) Altruism and community virtual practice as antecedents main For facilitate behavior share knowledge between nurse . Framework Work conceptual integrate theory cognitive social , social capital theory and TPB.

Source: Data Processed (2025)

H 6 : Altruism behavior positively influences Tacit Knowledge Sharing Frameworks

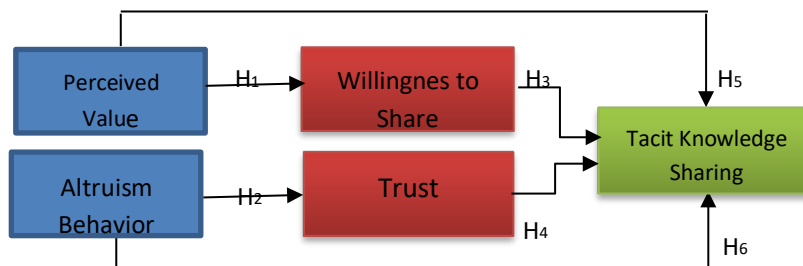

Figure 1. Framework

Source: Data Processed

Methods

This is being studied by Locus in private higher education institutions in Java to use nonprobability purposive sampling to make generalizations empirical. Election criteria respondent research These are: Lecturer who has been employed for at least five years at the institution of higher learning; Work in a position that allows them to innovate the work process. minimum sample need for the study This is two and a half times as much as was tracked in study models. The minimal sample size for the study model This is 170 respondents, however studies This amount unit observation as many as 280 respondents.

Table 7. Scale Variable Measurement

No	Variable name and indicator	Indicator Study
1	Altruism Behavior (David G. Myers, 2012)	<ol style="list-style-type: none"> 1. Empathy , feeling self they are most responsible answer , characteristic social , always adapt self , tolerant , able control self , and motivated For make good impression . _ 2. Belief on a just world, belief that in period wrong length will be punished and good will can gift . People who believe strong to world justice will motivated with easy show behavior help . 3. Social responsibility, responsible answer to whatever other people do , so when someone else needs it the person's help must help him . 4. Control self internally , Things done _ motivated by control of in himself (eg satisfaction self).
2	Perceived Value (Sweeney, 2001)	<ol style="list-style-type: none"> 1. Emotion value , derived utility from feeling or affective / emotional positive , with indicators : joy , pride , gratitude 2. Social value , utility obtained from ability something For increase draft self , with indicators : relations , cooperation , mutual support . 3. Information , utility obtained from perception to expected quality and performance , with _ indicators : accurate , speed , accuracy time .

		4. Entertainment , utilities from something such as , building personal branding, prestige , trust self .
3	Tacit Knowledge Sharing (Asbari et al., 2019)	<ol style="list-style-type: none"> 1. Transfer of knowledge is largely determined by credibility 2. the transferring party ' through interaction stare face . Share via analogies , metaphors , and stories experimental , intuitive , communicated through collaboration stare advance 3. Rules-of-thumb and capabilities imagine , maneuver physical , increase efficiency , formation and recognition image , etc handling connection man 4. shared through very interactive conversation , storytelling , sharing experience
4	Trust (Nguyen, 2014)	<ol style="list-style-type: none"> 1. Trustworthy, consider other trusted party For do something work 2. Benefits, believe that something activity will bring benefit 3. Promise, believe that the other party can keep promise 4. Job right, believe it that the other party can do work with right
5	Willingnes to Share (Wangpipatwong et al., 2009)	<ol style="list-style-type: none"> 1. Willingness share material studying to Friend 2. Willingness do discussion about new ideas with Friend 3. Willingness For share acquired knowledge _ to Friend 4. Willingness For accept input thinking Friend

		5. Willingness For collaborate
		6. Willingness For accept critics from Friend
		7. Willingness listen problems encountered _ Friend
		8. Willingness help solve problem Friend

Source: Data Processed (2025)

Analysis of Data

Structured Equation Modeling-Partial Least Square (SEM-PLS) - SMART PLS 5 (Becker et al., 2015) was used to evaluate survey data. Both the outer model and the inner structural model were evaluated using SEM-PLS. The average variance extracted test (AVE), the loading factor, the Fornell lesser criterion, and the cross-loading make up the outer model assessment for evaluating validity. Additionally, evaluation reliability is assessed using a composite. The structural model should pass several evaluations after the measurement model has been examined. Determine whether any relationship (between one construct and another construct) has a chance of matching and being approved. Rating of compatibility The entire model is not advised for every track in models or for assessments of compatibility of any type. because a large sample is biased against a small size overall. R^2 , predictive relevance Q^2 , size and significance coefficient path, f^2 , and evaluate q^2 are the metrics for evaluating measurement models.

Results and Discussion

280 people participated in the survey, but 4 responded. 274 responses were recorded as fit since there was no complete. Respondents include lecturers from a variety of Private Higher Education (PTS) in Java, each with a unique history and demographic. The 274 respondents who made up the sample are profiled demographically in Table 1 below.

Tabel 8. Respondents' Demographic Profile

Demographic Profiles	frequency	%	Demographic Profiles	frequency	%
Gender			Marital status		
Male	118	43.07%	Single/have not married	63	22.26%
Female	156	56.93%	Married	211	77.01%
Tenure			Education level		
Less than six years	12	4.38%	Bachelor degree	14	5.11%
1-5 years	76	27.74%	Grade 2	203	74.09%
6-10 years	81	29.56%	Grade 3	57	20.80%
11-15 years	83	30.29%	Academic positions		
More than fifteen years	22	8.03%	functional	2	0.73%
			Expert Assistants	8	0.00%
			Lector	111	2.92%
			Head Lecturer	51	40.51%
			Professor	4	18.61%

Source: Data Processed (2025)

Women now make up the majority in positions of power and hold the majority of master's degrees in terms of educational attainment. For working time, a sizable portion of respondents have jobs ranging from 11 to 15 years, with lecturer jobs making up a sizable portion of such jobs.

External Model Assessment

Because the build is a second-order construct, we first evaluate Perceive Value (PV) after evaluating the outer model. Each first-order construct's score latent variable is extracted using an approach indication that is repeated in the first order. Assess the requirements for validity and reliability for each concept in measurement models after loading the score latent variables. Table 4 lists the Fornell-Lacker, composite reliability, and AVE criteria. For each build, we are studying this.

Tabel 9. Each Construct's Validity and Reliability Criteria

construct	Composite reliability*	AVE**	Fornell-Lacker Criterion***				
			Altruism Behavior	Perceived Value	Tacit Knowledge Sharing	Trusts	Willingnes to Share
Altruism Behavior	0.916	0.731	0.855				
Perceived Value	0.918	0.784	0.454	0.696			
Tacit Knowledge Sharing	0.942	0.801	0.517	0.503	0.895		
Trusts	0.931	0.771	0.399	0.406	0.474	0.878	
Willingnes to Share	0.922	0.598	0.308	0.523	0.467	0.332	0.773

Source: Data Processed (2025)

AVE should be greater than 0.5 and composite reliability should be greater than 0.7. Fornell-Lacker The criteria should be more stringent than just how well that construct correlates with other constructs.

All constructs meet the AVE criteria (concurrent validity), composite reliability, and Fornell-Lacker criteria (discriminant validity and reliability) based on table 4 above. Besides As a result, the majority of outer loading (get see in attachment) for each indicator is greater than 0.7, and based on cross-loading values, all indicators have the highest loading values in their respective constructs, demonstrating that each construct has the maximum level of validity for the recognized discriminant.

Inner Model Evaluation

Following the external research model Table 5 lists the evaluation criteria that were employed.

This is for evaluating the internal research model.

Table 10. R-square, f-square, Q, and q-square

Construct	r-square	f-square	Q-square	q-square
Tacit Knowledge Sharing	0.438*	0.107**	0.343***	****
Trusts	0.223*	0.082**	0.164***	****
Willingnes to Share	0.273*	0.336**	0.160***	****

Source: Data Processed (2025)

Paths with r-square values below 0.5 are regarded as having weak predictive accuracy, while paths with f-square values above 0.35 are regarded as being large. Paths with Q-square values above 0 are regarded as having predictive relevance, while paths with Q-square values above 0.25 are regarded as having medium predictive relevance.

Table 5 displays The r-square values for four inner model criteria are low. The models' tracks all have low r-square levels. The size effect size construction exogenous indicated by f-square then shows that all track own size big influence. Finally, Q and q square demonstrate that every exogenous factor is a significant predictor of the endogenous variable.

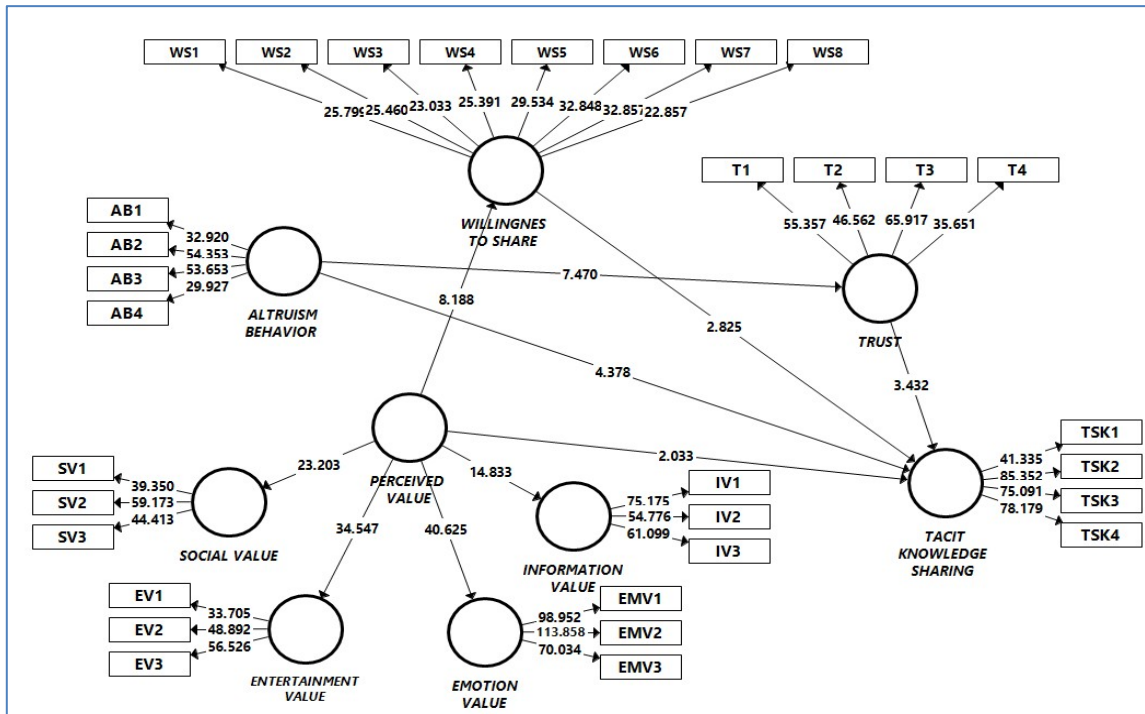

Figure 2 : Full SEM Model

Beta path and p value of two track in models. Beta path and p-value extracted of 500 bootstraps using SMART PLS5.

Table 11. Beta Path and P Value

Path	Path	t-	P-
	beta	value	values
Altruism Behavior à Tacit Knowledge Sharing	0.285	4,515	0.000
Altruism Behavior à Trust	0.270	4,371	0.000
Perceived Value à Tacit Knowledge Sharing	0.272	2,978	0.039
Perceived Value à Willingnes to Share	0.523	8.004	0.000
Trust à Tacit Knowledge Sharing	0.218	3,672	0.000

Willingnes To Share à Tacit Knowledge Sharing	0.216	2,709	0.007
---	-------	-------	-------

Source: Data Processed (2025)

As shown in Table above , to _ seven beta pathway is significant at 5%. Deep beta mark positive . this result support hypothesis 1 to 7 and stated accepted . Furthermore For test hypothesis mediation , yes seen in Table.

Table 11. Direct, indirect effects and VAF

Path	Value	Pvalue
Direct effect (Altruism Behavior à Tacit Knowledge Sharing) [1]	0.285	0.000
Indirect effect (Altruism Behavior à Trust à Tacit Knowledge Sharing) [2]	0.059	0.017
Total effect (direct +indirect) [3]	0.344	
VAF ([2] / [3])	0.172	
Direct effect (Perceived Value à Tacit Knowledge Sharing) [1]	0.272	0.039
Indirect effect (Perceived Value à Trust à Tacit Knowledge Sharing) [2]	0.062	0.003
Total effect (direct +indirect) [3]	0.334	
VAF ([2] / [3])	0.186	
Direct effect (Perceived Value à Tacit Knowledge Sharing) [1]	0.272	0.039

Indirect effect (Perceived Value →Willingness to Share →Tacit Knowledge Sharing) [2]	0.113	0.019
Total effect (direct +indirect) [3]	0.385	
VAF ([2] / [3])	0.294	

Source: Data Processed (2025)

According to Table, there is a mark influence of 0.059 and a significant value of 1% towards the sharing of tacit knowledge. influence Through trust of 0.062, and value the significant at 1% level, tacit information sharing is shared with no direct perceived benefit. Influence There is little direct perceived value to sharing tacit information, and willingness to share is only 0.113, with value at the 1% level. With this in mind, it is stated that mediation and being willing to share are worthy of becoming mediation. Besides As a result, the VAF value for each of 0.172 or 17.2%, 18.6 or 18.6%, and 0.294 or 29.4% is below 80%, demonstrating that the mediation is only partial. Because of this, it may be inferred that trust and openness to share can mediate the connection between tacit information sharing and altruism behavior, as well as the perceived value of tacit knowledge sharing.

Discussion Findings This is consistent with the underlying assumptions of the behavior plan and the large body of data. This means that attitudes and tacit knowledge both influence behavior. in light of _ That study This discovery will serve as an intermediary mediator for behavior, sharing knowledge, and personality traits while also influencing and sharing tacit knowledge. Momentary plan behavior and alternative choice analysis Choosing one of the many alternatives will help you achieve your objective. People will willingly share their experiences with others under the condition of receiving feedback when they believe that collective effort will make the settlement's targeted job _ more likely. _ Lecturer will impart knowledge to help students acquire the skills they need to complete tasks. because when there is a clear connection between effort and result, or when people feel that working together makes

results more meaningful, ready to lecture for one another to share exert conduct increases. Generally speaking, business management is the lecturer's main area of expertise for effectively inspiring knowledge sharing (Wang, JS, Lin, CW, Yang, YTC, & Ho, 2012), yet occasionally lecturers have a tendency to view knowledge as a source of authority and control (Anitha Chennamanini, 2012).

Results of interviews with various leaders The higher the frequency of internal and external conversations held on campus by lecturers, according to the college, has an impact on student achievement in higher education. Here, the focus is on role management and useful knowledge, which are recognized as the basics of education at every level for achieving goals. Educational institutions strive to expand students' partial knowledge, which is then stored in their memory and used by lecturers to add value and foster achievement.

Implementation management knowledge college effective height, require maximum handling, through application appropriate policy, so that capable increase quality education For answer vision and mission institution. one _ policy like an innovative learning process for lecturers, through practice each other share knowledge, because share knowledge is a vital process for the world of education. and enables the sharing of knowledge. Always keep in mind that knowledge is a valuable thing, yet some people have a tendency to hoard it. Because of a variety of factors, including the fact that sharing knowledge among lecturers is an action volunteer for improving the standard of higher education. People are encouraged to think creatively by the tacit knowledge that exists among them, as creative thinking can also occur when people share their information.

He responded by carrying out the tri dharma of the university tall with more ok. Condition furthermore individual lecturer capable think systemic For finish results his work, and able deepen mastery self through belief self so that can increase knowledge and skills as well as finish duties and responsibilities. According to (Obrenovic et al., 2020), empathy is the capacity for understanding the thoughts, feelings, and emotions of others as well as the capacity for

putting oneself in their shoes. Here, the ability to use knowledge and the frequency and quality of lecturer-student interaction determine whether tacit knowledge is successfully shared.

Conclusion

Study's finding This is because behavior altruism is the best indicator of how eagerly lecturers will want to share their expertise with students and outside parties. Perceived value support is also a crucial determinant of how eagerly lecturers will want to offer their information. conclusions from the data This requires creating a culture where knowledge is routinely shared through discussion at the study program level, the lowest structural level, and at the level of the faculty and universities. Additionally, there should be discussion with party external Good fellow academics or with nonacademicians. Finally, the activity must be covered by academic regulations that guarantee quality as a tool for control. All of these ideas are capable of improving lecturer caliber and bringing about the Tri Dharma of Higher Education.

Weakness analyses Because recommendations for future research must include variables as variables in the research, this is not yet able to identify problems in education that are complex enough to share knowledge related to pavilions, finance colleges, recruitment, and maintenance processes lecturer.

References

- Agustina, R., Yusuf, M., Sutiyan, O. S. J., Ardianto, R., & Norvadewi, N. (2022). Employee Performance Mediated Quality Of Work Life Relationship Satisfaction On The Job And Organizational Commitment. *Jurnal Darma Agung*, 30(2), 589-605.
- Anitha Chennamaneni, J. T. C. T. & M. K. R. (2012). A unified model of knowledge sharing behaviours: theoretical development and empirical test. *Behaviour & Information Technology*, 31(11), 1097–1115.
<https://doi.org/doi.org/10.1080/0144929X.2011.624637>

- Asbari, M., Wijayanti, L. M., Hyun, C. C., Purwanto, A., & Santoso, P. B. (2019). Effect of Tacit and Explicit Knowledge Sharing on Teacher Innovation Capability. *Dinamika Pendidikan*, 14(2), 227–243. <https://doi.org/10.15294/dp.v14i2.22732>
- Becker, J. M., Ringle, C. M., Sarstedt, M., & Völckner, F. (2015). How collinearity affects mixture regression results. *Marketing Letters*, 26(4), 643–659. <https://doi.org/10.1007/s11002-0149299-9>
- Behavior. *Frontiers in Psychology*, 11(July), 1–16. <https://doi.org/10.3389/fpsyg.2020.01496>
- Ogunmokun, O. A., Eluwole, K. K., Avcı, T., Lasisi, T. T., & Ikhıde, J. E. (2020). Propensity to trust and knowledge sharing behavior: An evaluation of importance-performance analysis among Nigerian restaurant employees. *Tourism Management Perspectives*, 33(October 2019), 100590. <https://doi.org/10.1016/j.tmp.2019.100590>
- Brühlhart, M., & Usunier, J. (2008). Verified Trust: Reciprocity, Altruism, And Randomness In Trustgames.
- Business, C. (2005). Knowledge sharing and methods of communication in high technology firms . *Knowledge Creation Diffusion Utilization*, 1–13.
- Castañeda, D. I. (2015). Variables in Leaders and Collaborators. 22(1), 63–69.
- David G. Myers. (2012). Psikologi Sosial Social Psychology (10th ed.). Salemba Humanika.
- Donald Hislop, Rachelle Bosua, R. W. H. (2018). Knowledge Management in Organizations: a critical introduction (4th ed.). Oxford University Press.
- Du, T. C., Lai, V. S., Cheung, W., & Cui, X. (2012). Willingness to share information in a supply chain: A partnership-data- process perspective. *Information and Management*, 49(2), 89–98. <https://doi.org/10.1016/j.im.2011.10.003>
- Gallarza & Saura. (2006). Value dimensions, perceived value, satisfaction and loyalty: an investigation of university students' travel behaviour. *Value Dimensions, Perceived Value, Satisfaction and Loyalty: An Investigation of University Students' Travel Behaviour*, 27(3), 437–452. <https://doi.org/dx.doi.org/10.1016/j.tourman.2004.12.002>

- Gamble, J. R. (2020). Tacit vs explicit knowledge as antecedents for organizational change. In *Journal of Organizational Change Management* (Vol. 33, Issue 6). <https://doi.org/10.1108/JOCM-04-2020-0121>
- Garcia-Perez, A., Cegarra-Navarro, J. G., & Jahantab, M. M. (2018). Knowledge Sharing as a Driver of Competitive Advantage: Two Cases from the Field. *Knowledge Management and Organizational Learning*, 6(May 2021), 145–167. https://doi.org/10.1007/978-3-319-668901_8
- Gosain, S., Malhotra, A., & El Sawy, O. A. (2004). Coordinating for flexibility in e-business supply chains. *Journal of Management Information Systems*, 21(3), 7–45. <https://doi.org/10.1080/07421222.2004.11045816>
- Holste, J. S., & Fields, D. (2010). Trust and tacit knowledge sharing and use. *Journal of Knowledge Management*, 14(1), 128–140. <https://doi.org/10.1108/13673271011015615>
- Honeycutt, J. M. (2014). Altruism and Social Exchange Theory: the Vicarious Rewards of the Altruist. *Social Thought and Research*, June. <https://doi.org/10.17161/str.1808.4880>
- Islam, Jasimuddin, & H. (2015). Organizational culture, structure, technology infrastructure and knowledge sharing. *Vine*, 45(1), 67–88. <https://doi.org/10.1108/vine-05-2014-0037>
- Khalil, E. L. (2001). Adam smith and three theories of altruism. *Recherches Economiques de Louvain*, 67(4), 421–435. <https://doi.org/10.3917/rel.674.0421>
- Khoa, B. T., Huynh, L. T., & Nguyen, M. H. (2020). The relationship between perceived value and peer engagement in sharing economy: A case study of ridesharing services. *Journal of System and Management Sciences*, 10(4), 149–172. <https://doi.org/10.33168/JSMS.2020.0410>
- Krylova, K.O., Vera, D. and Crossan, M. (2016). Knowledge transfer in knowledge-intensive organizations: the crucial role of improvisation in transferring and protecting

- knowledge. *Journal of Knowledge Management*, 20(5), 1045–1064.
<https://doi.org/doi.org/10.1108/JKM10-2015-0385>
- Lin. (2007). Knowledge sharing and firm innovation capability: an empirical study. *International Journal of Manpower*, 28(3/4), 315–332.
<https://doi.org/doi.org/10.1108/01437720710755272>
- Mahmood, A., Tasmin, R., Saeed, B., & Saeed, A. (2020a). Tacit Knowledge Sharing In Technology-Based Firms : Role Of Organization Citizenship Behavior And Perceived Value Of Knowledge. May.
- Mahmood, A., Tasmin, R., Saeed, B., & Saeed, A. (2020b). Tacit knowledge sharing in technologybased firms: Role of organization citizenship behavior and perceived value of knowledge. *International Journal of Scientific and Technology Research*, 9(3), 5296–5302.
- Manus, P. M., Ragab, M., Arisha, A., & Mulhall, S. (2016). Review of factors influencing employees' willingness to share knowledge. *Proceedings of the European Conference on Knowledge Management, ECKM, 2016-Janua*, 586–595.
- Matić, Cabrilo, Grubić-Nešić, & M. (2017). Investigating the impact of organizational climate, motivational drivers, and empowering leadership on knowledge sharing. *Knowledge Management Research & Practice*, 15(2). <https://doi.org/10.1057/s41275-017-0063-9>
- Matzler, K., Bidmon, S., & Grabner-Kräuter, S. (2006). Individual determinants of brand affect: The role of the personality traits of extraversion and openness to experience. *Journal of Product and Brand Management*, 15(7), 427–434.
<https://doi.org/10.1108/10610420610712801>
- Mohajan, H. K. (2019). Knowledge Sharing among Employees in Organizations. *Journal of Economic Development, Environment and People*, 8(1), 52.
<https://doi.org/10.26458/jedep.v8i1.612>

- Natek, S., & Lesjak, D. (2021). Knowledge management systems and tacit knowledge. *International Journal of Innovation and Learning*, 29(2), 166–180.
<https://doi.org/10.1504/IJIL.2021.112994>
- Nesic, A., & Lalic, D. (2016). The Impact of Trust on Job Performance in Organisations. *Management - Journal for Theory and Practice of Management*, 21(81), 27–34.
<https://doi.org/10.7595/management.fon.2016.0028>
- Nguyen, et all. (2014). The exoskeletal structure and tensile loading behavior of an ant neck joint. *Journal of Biomechanics*, 47(2), 497–504.
<https://doi.org/https://doi.org/10.1016/j.jbiomech.2013.10.053>
- Nham, T. P., Tran, N. H., & Nguyen, H. A. (2020). Knowledge sharing and innovation capability at both individual and organizational levels: An empirical study from Vietnam’s telecommunication companies. *Management and Marketing*, 15(2), 275–301. <https://doi.org/10.2478/mmcks-2020-0017>
- Ni, E. C., & Ganesharatnam, S. (2022). JOURNAL OF BUSINESS AND SOCIAL SCIENCES eISSN:2805-5187 Vol.2022:017. *Journal of Business and Social Sciences*, 2022(August).
- Obrenovic, B., Jianguo, D., Tsoy, D., Obrenovic, S., Khan, M. A. S., & Anwar, F. (2020). The Enjoyment of Knowledge Sharing: Impact of Altruism on Tacit Knowledge-Sharing
- Pfattheicher, S., Nielsen, Y. A., & Thielmann, I. (2022). Prosocial behavior and altruism: A review of concepts and definitions. *Current Opinion in Psychology*, 44(August), 124–129. <https://doi.org/10.1016/j.copsyc.2021.08.021>
- Philipson, S., & Kjellström, E. (2020). When objects are talking: How tacit knowing becomes explicit knowledge. *Journal of Small Business Strategy*, 30(1), 68–82.
- Ramdani, D., & Azzahra, G. A. (2024). Analysis of consumer preference to price strategies in the retail industry. *Journal of Student Collaboration Research*, 1(1), 53-62.

- Ramdani, D., & Pauzi, M. (2025). Quality of Public Services in the field of Population Administration in Jatinangor District Sumedang Regency. *DECISION: Jurnal Administrasi Publik*, 7(1), 26-31.
- Samadi, B., Wei, C. C., Seyfee, S., & Yusoff, W. F. W. (2015). Conceptual model of organizational trust and knowledge sharing behavior among multigenerational employees. *Asian Social Science*, 11(9), 32–42. <https://doi.org/10.5539/ass.v11n9p32>
- Sentika, S., & Arissaputra, R. (2022). Knowledge Sharing is The Key Success Factor to Building Competitive Advantage in Indonesia: a Review and Hint for Future Research. *Budapest International Research and Critics Institute (BIRCI-Journal)*, 3095–3103. <https://doi.org/10.33258/birci.v5i1.3958>
- Shaari, R., Bakri, N., & Mannan, A. A. (2015). ScienceDirect Antecedents of Knowledge Sharing Behavior among Nurses : Towards Research Agenda. *Procedia - Social and Behavioral Sciences*, 171, 635–641. <https://doi.org/10.1016/j.sbspro.2015.01.171>
- Slonim, R., & Garbarino, E. (2008). Increases in trust and altruism from partner selection : Experimental evidence. *Increases in trust and altruism from partner selection : Experimental evidence*. January 2015. <https://doi.org/10.1007/s10683-007-9162-4>
- Siregar, A. P., Nofirman, N., Yusuf, M., Jayanto, I., & Rahayu, S. (2022). The Influence of Taste and Price on Consumer Satisfaction. *Quantitative Economics and Management Studies*, 3(6), 998-1007.
- Siregar, N., Nursyamsi, S. E., Sutaguna, I. N. T., Razali, G., & Yusuf, M. (2023). DIGITAL MARKETING TO E-COMMERCE CUSTOMERS. *Journal of Management and Creative Business*, 1(2), 182-198.
- Solorzano, C. S., Panasiti, M. S., Pucchio, A. Di, & Grano, C. (2022). The Impact of Positivity and Parochial Altruism on Protective Behaviours during the First COVID-19 Lockdown in Italy.

- Soukotta, A., Sampe, F., Putri, P. A. N., Cakranegara, P. A., & Yusuf, M. (2022). FINANCIAL LITERACY AND SAVINGS BEHAVIOR FEMALE ENTREPRENEURS IN KIARACONDONG MARKET, BANDUNG CITY. *Jurnal Darma Agung*, 30(2), 652-662.
- Soukotta, A., Yusuf, M., Zarkasi, Z., & Efendi, E. (2023). Corporate Actions, Earning Volatility, And Exchange Rate Influence On Stock Price Stability. *Inisiatif: Jurnal Ekonomi, Akuntansi dan Manajemen*, 2(2), 197-214.
- Sucipto, B., Yusuf, M., & Mulyati, Y. (2022). Performance, Macro Economic Factors, And Company Characteristics In Indonesia Consumer Goods Company. *Riwayat: Educational Journal of History and Humanities*, 5(2), 392-398.
- Sudirjo, F., Lotte, L. N. A., Sutaguna, I. N. T., Risdwiyanto, A., & Yusuf, M. (2023). THE INFLUENCE OF GENERATION Z CONSUMER BEHAVIOR ON PURCHASE MOTIVATION IN E-COMMERCE SHOPPE. *Profit: Jurnal Manajemen, Bisnis dan Akuntansi*, 2(2), 110-126.
- Sudirjo, F., Ratnawati, R., Hadiyati, R., Sutaguna, I. N. T., & Yusuf, M. (2023). THE INFLUENCE OF ONLINE CUSTOMER REVIEWS AND E-SERVICE QUALITY ON BUYING DECISIONS IN ELECTRONIC COMMERCE. *Journal of Management and Creative Business*, 1(2), 156-181.
- Sudirjo, F., Sutaguna, I. N. T., Silaningsih, E., Akbarina, F., & Yusuf, M. (2023). THE INFLUENCE OF SOCIAL MEDIA MARKETING AND BRAND AWARENESS ON CAFE YUMA BANDUNG PURCHASE DECISIONS. *Inisiatif: Jurnal Ekonomi, Akuntansi dan Manajemen*, 2(3), 27-36.
- Sutaguna, I. N. T., Razali, G., & Yusuf, M. (2023). Hanan Catering's Instagram promotions, pricing, and menu variety influence consumer purchasing decisions in Bandung. *International Journal of Economics and Management Research*, 2(1), 76-87.

- Sutaguna, I. N. T., Sampe, F., Dima, A. F., Pakiding, D. L., & Yusuf, M. (2022). Compensation and Work Discipline's Effects on Employee Achievement at Perumda Pasar Juara. *YUME: Journal of Management*, 5(3), 408-428.
- Sutaguna, I. N. T., Yusuf, M., Ardianto, R., & Wartono, P. (2023). The Effect Of Competence, Work Experience, Work Environment, And Work Discipline On Employee Performance. *Asian Journal of Management, Entrepreneurship and Social Science*, 3(01), 367-381.
- Sutrisno, S., Herdiyanti, H., Asir, M., Yusuf, M., & Ardianto, R. (2022). Dampak Kompensasi, motivasi dan Kepuasan Kerja Terhadap Kinerja Karyawan di Perusahaan: Review Literature. *Management Studies and Entrepreneurship Journal (MSEJ)*, 3(6), 3476-3482.
- Sutrisno, S., Panggalo, L., Asir, M., Yusuf, M., & Cakranegara, P. A. (2023). Literature Review: Mitigasi Resiko dan Prosedur Penyelamatan pada Sistem Perkreditan Rakyat. *COSTING: Journal of Economic, Business and Accounting*, 6(2), 1154-11
- Sweeney, J. G. N. S. (2001). Consumer perceived value: The development of a multiple item scale. *Journal of Retailing*, 77(2), 203–220
[https://doi.org/https://doi.org/10.1016/S00224359\(01\)00041-0](https://doi.org/https://doi.org/10.1016/S00224359(01)00041-0)
- Szilva, Caganova, Bawa, Pechanova, & H. (2018). Knowledge Management Perception in Industrial Enterprises Within the CEE Region. *Lecture Notes of the Institute for Computer Sciences*. https://doi.org/10.1007/978-3-319-67636-4_8
- Wang, J. S., Lin, C. W., Yang, Y. T. C., & Ho, Y. (2012). Walking pattern classification and walking distance estimation algorithms using gait phase information. *IEEE Transactions on Biomedical Engineering*, 59(10), 2884–2892.
<https://doi.org/doi.org/10.1109/TBME.2012.2212245>
- Wang, Y. (2013). Tacit Knowledge in Community of Practice: Implications of using Social Communication Tools. 85.

- Wangpipatwong, S., Chutimaskul, W., & Papasratorn, B. (2009). Quality enhancing the continued use of e-government web sites: Evidence from e-citizens of Thailand. *International Journal of Electronic Government Research*, 5(1), 19–35.
<https://doi.org/10.4018/jegr.2009092202>
- Widjaja, W., Kartini, T., Yuningsih, E., Yusuf, M., & Hayati, F. A. (2023). KAHATEX BANDUNG REGENCY'S EMPLOYEE SELECTION AND PLACEMENT IMPACT. *Transformasi: Journal of Economics and Business Management*, 2(2), 72-84.
- Wowling, S. A. S., Yusuf, M., Gampu, S., & Sahala, J. (2022). PRODUCT QUALITY AND PRICING INFLUENCE ON THE BRAND REPUTATION OF LOCO COFFEE FAST FOOD PRODUCTS. *Jurnal Darma Agung*, 30(2), 541-548
- Yusuf, M., & Matiin, N. (2022). ANALYSIS OF THE EFFECT OF THE MARKETING MIX ON PURCHASING DECISIONS. *International Journal of Economics and Management Research*, 1(3), 177-182.
- Yusuf, M., Fitriyani, Z. A., Abdilah, A., Ardianto, R., & Suhendar, A. (2022). The Impact Of Using Tokopedia On Profitability And Consumer Service. *Jurnal Darma Agung*, 30(2), 559-573.
- Yusuf, M., Haryono, A., Hafid, H., Salim, N. A., & Efendi, M. (2022). Analysis Of Competence, Leadership Style, And Compensation In The Bandung City Pasar Bermartabat. *Jurnal Darma Agung*, 30(1), 524-2.
- Yusuf, M., Saiyed, R., & Sahala, J. (2022, December). Swot Analysis in Making Relationship Marketing Program. In *Proceeding of The International Conference on Economics and Business* (Vol. 1, No. 2, pp. 573-588).
- Yusuf, M., Sutrisno, S., Putri, P. A. N., Asir, M., & Cakranegara, P. A. (2022). Prospek Penggunaan E-Commerce Terhadap Profitabilitas Dan Kemudahan Pelayanan Konsumen: Literature Review. *Jurnal Darma Agung*, 30(1), 786-801

Zhao, J., Zhu, C., Peng, Z., Xu, X., & Liu, Y. (2018). User willingness toward knowledge sharing in social networks. *Sustainability (Switzerland)*, 10(12), 1–27.
<https://doi.org/10.3390/su10124680>